

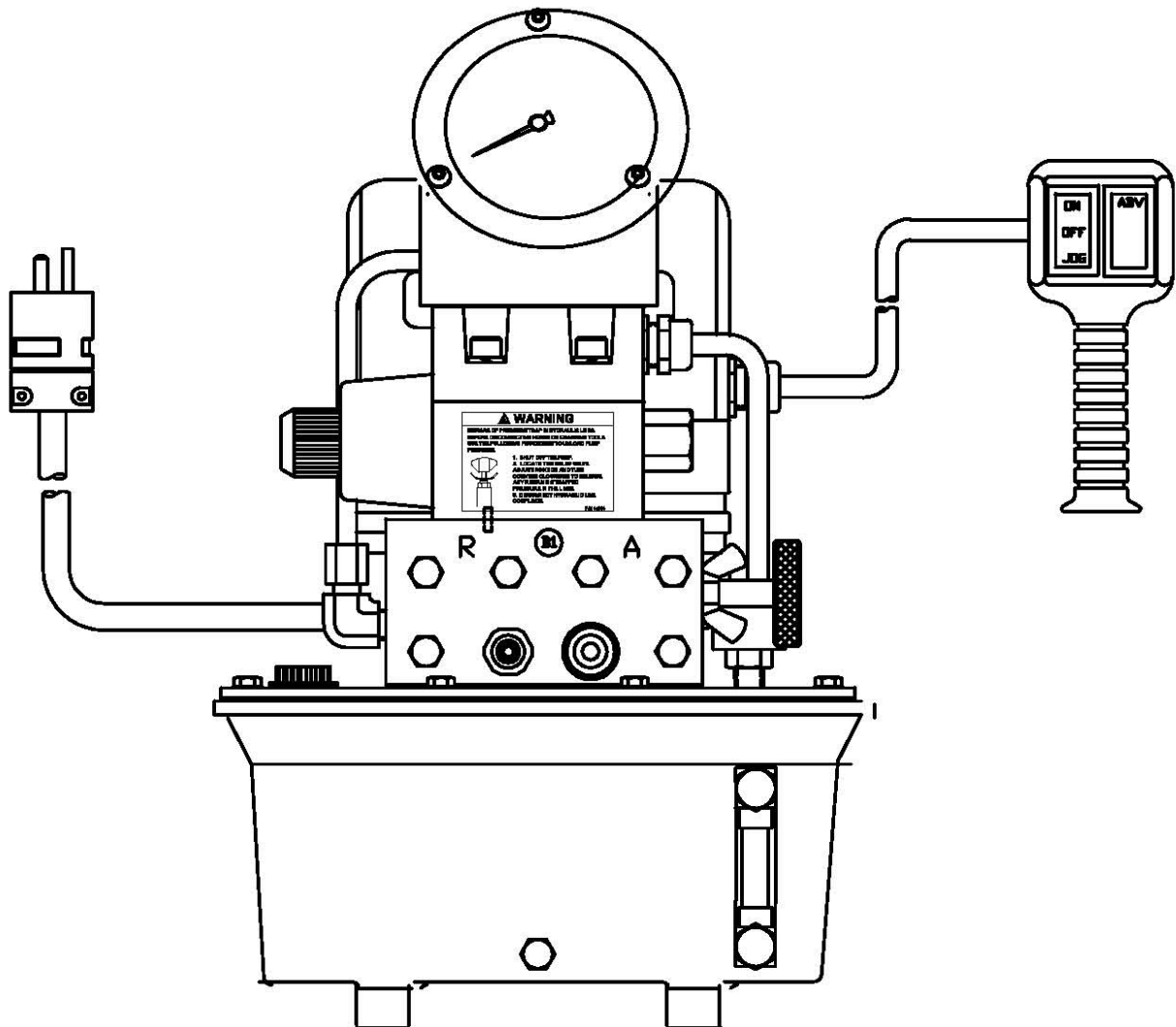

**Worldwide Headquarters**  
1025 Conroy Place, Easton, PA 18040  
United States of America  
Phone: 610-250-5800  
Fax: 610-250-2700  
Toll Free: 1-888-TORCUP-1  
E-mail: sales@torcup.com  
Website: www.torcup.com

## Torque Wrench Power Pump EP1000-Q-230V

Operating & Maintenance Instructions  
For 1 ½ hp 230V. Power Pump



Version 1  
Feb. 2008

## WARNING

**IMPORTANT SAFETY INFORMATION ENCLOSED.  
READ THIS MANUAL BEFORE OPERATION.  
IT IS THE RESPONSIBILITY OF THE EMPLOYER TO PLACE THE INFORMATION IN THIS MANUAL INTO  
THE HANDS OF THE OPERATOR.  
FAILURE TO OBSERVE THE FOLLOWING WARNINGS COULD RESULT IN INJURY.**

The use of other than genuine TorcUP replacement parts may result in safety hazards, decreased tool performance, and increased maintenance, and may invalidate all warranties.

Repairs should be made only by authorized personnel. Consult your nearest TorcUP Authorized Service Center. Refer all communications to the nearest TorcUP Office or Distributor.

## WARNING

For Technical Support and Information Contact:  
TorcUP, Inc.  
1025 Conroy Place, Easton, PA 18040  
Toll Free: (888) TORCUP-1 Fax: (610) 250-2700  
E-mail: info@torcup.com

## FAILURE TO OBSERVE THE FOLLOWING WARNINGS COULD RESULT IN INJURY

- Keep hands, loose clothing and long hair away from the reaction arm and working area during operation. Do not attempt to support the tool with your hands during operation.
- This tool will exert a strong reaction force. Use proper mechanical support and correct reaction arm positioning to control these forces. Do not position the reaction arm so that it tilts the tool off the axis of the bolt and never use the swivel inlets as a reaction stop.

Avoid sharp bends and kinks that will cause severe back-up pressure in hoses and lead to premature hose failure.

- Use accessories recommended by TorcUP.
- Use only impact sockets and accessories. Do not use hand (chrome) sockets or accessories.
- Use only sockets and accessories that correctly fit the bolt or nut and function without tilting the tool off the axis of the bolt.
- This tool is not designed for working in explosive atmospheres

Always wear eye protection when operating or performing maintenance on this tool.



Always wear ear protection when operating this tool.



Keep body stance balanced and firm. Do not overreach when operating this tool.



Operate at 10,000 psig (681bar) maximum pressure.

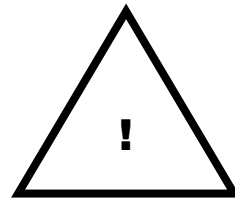

Do not use damaged, frayed or deteriorated hydraulic hoses and fittings.



Always turn off the pump and disconnect the power before installing, removing, or adjusting any accessory on this tool, or before performing any maintenance on this tool.



Do not carry the tool by the hose.



The Torque Reaction Arm must be positioned against a positive stop. Do not use the Arm as a dead handle. Take all precautions to make certain the operator's hand cannot be pinched between the Arm and a solid object.



## NOTICE

**SAVE THESE INSTRUCTIONS. DO NOT DESTROY.**

## OPERATING INSTRUCTIONS AT A GLANCE

### Before Operating Pump:

1. Be sure the electrical connection is grounded. Check that your power supply agrees with the motor nameplate.
2. Use only torque wrench, hoses and equipment rated at 10,000 PSI.
3. Make sure all hose and fitting connections are tight and secure. Hoses cannot be kinked or twisted.
4. Oil level should be 1" to 2" from the reservoir plate.
5. Loosen lock nut and back out relief valve to prevent unintended pressure build-up.
6. Never operate the pump with the directional control valve in advance or retract at 10,000 PSI without wrench movement for more than 1 minute. Leaving the valve in the advance or retract position without the wrench moving will overheat the oil.

### After Completing the Job:

1. Before disconnecting hoses, fittings, etc., be sure the wrench is retracted and unloaded, then unplug the power cord.
2. Store the pump in a clean, dry area.

### Periodic Maintenance:

1. Completely change the hydraulic oil and clean the oil filter screen and magnet [located in the reservoir] twice a year. [Use TorcUP approved oil only, 2 gallon]. Change the oil more frequently when used in extremely dusty areas or when the oil has been overheated. Using oil other than TorcUP approved oil voids the pump warranty

## OPERATING INSTRUCTIONS FOR: EP1000 Q 230V

**Max. Capacity: 10,000PSI**

### NOTE:

- Carefully inspect the pump upon arrival. The carrier, not the manufacturer, is responsible for any damage resulting from shipment. Visually inspect all components for shipping damage. If any damage is found, notify carrier immediately.
- Remove pump from shipping container – but do not remove any plugs or valves until the unit is ready to be fully assembled to prevent dirt or foreign matter from contaminating system.
- Read carefully follow these instructions. Most problems with new equipment are caused by improper operation or installation.
- Do not change motors without consulting the pump manufacturer's Technical Services Department.

**SAFETY PRECAUTIONS    WARNING:** To help prevent injury.

### HYDRAULIC HOSE

- Before operating the pump, all hose connections must be tightened with the proper tools. Do not over tighten. Connections should only be tightened securely and leak-free. Over tightening can cause premature thread failure or high pressure fittings to split at pressures lower than their rated capacities.
- Never disconnect or connect any hydraulic hoses or fitting without first unloading the wrench. Double check the gauge to ensure pressure has been released. When making connections with quick disconnect couplings, make sure the couplings are fully engaged. Threaded connections such as fittings, gauges, etc. must be securely tightened and leak free.
- Always shut off the electric motor before breaking any connections in the systems.
- Loose or improperly threaded fittings can be potentially dangerous if pressurized, however, severe over tightening can cause premature thread failure. Fittings need to be tightened secure and leak free.
- Never hold and stand directly in line with any hydraulic connections while pressurizing.
- Never grab, touch or in any way come in contact with a hydraulic pressure leak. Escaping oil can penetrate the skin and serious injury can result.
- Should a hydraulic hose ever rupture, burst, or need to be disconnected, immediately shut off the pump. Never attempt to grasp a leaking pressurized hose with your hands. The force of escaping hydraulic fluid could cause serious injury.
- Do not subject the hose to potential hazard such as fire, sharp surfaces, extreme heat or cold, or heavy impact. Do not let the hose kink, twist, curl or bend so tightly that the oil flow within the hose is blocked or reduced. Periodically inspect the hose for wear, because any of these conditions can damage the hose.
- Do not use the hose to move attached equipment. Stress can damage the hose, causing injury.
- Inspect each hose for wear before each use.
- Hose material and coupler seals must be compatible with the hydraulic fluid used. Hoses also must not come in contact with corrosive materials such as creosote-impregnated objects and some paints. Consult the manufacturer before painting a hose. Never paint the couplers. Hose deterioration due to corrosive materials can result in injury.

### PUMP

- Do not exceed the PSI hydraulic pressure rating noted on the pump nameplate or tamper with the internal high pressure relief valve. Creating pressure beyond rated capacities can result in equipment failure and/or injury.
- The pump's maximum working pressure is 10,000 PSI (700kg/cm). Make sure that all hydraulic equipment such as wrench, hoses, etc. used with this pump is rated at 10,000 PSI operating pressure.
- Before replenishing the oil level, retract the system to prevent overfilling the pump reservoir. An overfill can cause injury due to excess reservoir pressure created when the cylinders are retracted.

### TORQUE WRENCHES

- Do not exceed the rated capacities of the torque wrenches. Excess pressure can result in injury.

Con't...

## **OPERATING INSTRUCTIONS FOR: EP1000 Q 230V**

### **POWER SUPPLY (Air Driven Motor)**

- Disconnect air supply when pump is not in use or when breaking any connection in the hydraulic system.
- An air shut-off valve or quick connect is installed in the air line to the pump unit. Close the shut-off valve before connecting the air line to the pump.

### **INSTRUCTIONS BEFORE USE**

**Hydraulic Connections:** Check hydraulic oil level to prevent possible pump burnout. Open the red plastic plug located on the reservoir plate. Oil level should be approximately 1" from top of reservoir plate – with cylinders retracted and motor off. Add TorcUP approved oil as necessary. Do not mix different grades of oil. Loosen lock nut and back out (turn counter-clockwise) relief valve to prevent unintended pressure buildup. Make sure all desired gauge, hose and quick coupler connections are tight and secure before operating. The pump's pressure ports are located just below the control valve.

**Hose Connections:** Couple hoses to pump outlet manifold. "A" port is for advancing and "B" port is for retracting the piston on the torque wrench. Pump is supplied with the specified coupling halves already connected to the pump ports to prevent incorrect coupling of hoses to wrench. Couple hoses to torque wrench. When using TorcUP pump and torque wrench combination, Series HPH hoses and couplers are designed so that the pump advance port can only be connected to the wrench advance port, and the pump retract port can only be connected to the wrench retract port.

## OPERATION

### Pump Operation:

1. Check all system fittings and connections to be sure they are tight and leak free.
2. Check oil level in reservoir. Oil level should be 1" to 2" from the top of the reservoir plate.
3. Be sure that the pump is "OFF"
4. Be sure the electrical connection is grounded. Check that your power agrees with the motor nameplate. Plug power cord into outlet.
5. Press "ON" on the pump switch to turn power on. Pressing the "ON" activates the electrical circuit, but does not turn the motor on. The pump motor is activated by the pendant switch.
6. Pendants supplied with the pumps have a momentary switch. Press momentary switch for "ADVANCE". Release "ADVANCE" and torque wrench piston will retract.

**NOTE:** The electrical motor stays running after pump has stopped. Within 15 seconds of your last command from the pendant, motor will turn off, preventing heat buildup.

### Air removal:

When the wrench is first connected to the pump, to ensure smooth and safe operation, remove air by cycling wrench several times without load. Cycle until wrench advances and retracts without hesitation.

### Pressure torque setting:

**!! WARNING !!** Make these adjustments BEFORE putting torque wrench on nut or bolt head. The pump pressure setting may be above the pressure needed to provide the required torque for your application. Exceeding required torque will cause equipment damage and may lead to serious personal injury.

1. See torque wrench instructions for amount of pressure required to produce desired torque.
2. Loosen lock nut and back out relief valve to prevent unintended pressure build-up.
3. Turn pump on. Press and hold the "ADVANCE" switch, and read pressure gauge.
4. While holding the switch, turn relief valve in (clockwise) to increase pressure or out (counter-clockwise) to decrease maximum pressure. Repeat until correct pressure is obtained.
5. Tighten lock nut on the relief valve to maintain setting.
6. Run pump several times to test this setting.

**REFER TO TORQUE WRENCH INSTRUCTIONS FOR WRENCH OPERATING PROCEDURE.**

## MAINTENANCE

**WARNING: THE ELECTRICAL POWER CORD MUST BE DISCONNECTED FROM ELECTRICAL OUTLETS BEFORE PERFORMING MAINTENANCE OR REPAIR PROCEDURES.**

### **Maintain Oil Level:**

Check hydraulic oil level every 30 hours of operation. Add TorcUP approved oil when necessary. Oil level should be no more than 1" from top of reservoir plate.

Completely change oil at least twice a year. The following conditions require more frequent oil changes:

- a. Rigorous duty, where oil temperature may reach 140 F.
- b. High humidity environment and extreme changes in temperature that can result in condensation inside the reservoir.
- c. Dirty or dusty environments that may contaminate the oil.

### **Clean Oil Filter Screen Once a Year:**

- a. Loosen and remove reservoir plate bolts. Lift pump unit off the reservoir, being careful not to damage the gasket.
- b. Unscrew screen from the bottom of pump unit and clean with nonflammable solvent.
- c. Blow dry and reassemble.

Keep areas around pump unobstructed to provide good airflow around the motor and pump. Keep the motor and pump as clean as possible.

### **Flushing the Pump:**

If you suspect your pump has been contaminated or discover sludge or other deposits on internal components, you should thoroughly flush the pump.

- a. Remove the old oil from the reservoir, then thoroughly clean the reservoir and refill with clean, non-flammable flushing oil.
- b. Reassemble the pump and motor to the reservoir.
- c. Now run the pump with no pressure for 1 or 2 minutes maximum.
- d. Unplug the pump and remove the motor and pump assembly again. Now drain the flushing oil and reclean the inside of the reservoir. (Make sure flushing fluid is also drained from pump assembly).

**Refill the reservoir with TorcUP approved hydraulic oil and reassemble the pump.**

## TROUBLESHOOTING

If the procedures listed below do not remedy the problem -- the pump will require service and should be taken to an authorized service center for repair.

<b>Problem</b>	<b>Cause/Solution</b>
Motor Will Not Start	Be sure power cord is not damaged. Check for tripped circuit breaker--be sure breaker is of adequate size. Have qualified electrician inspect for loose or faulty wiring. Have motor checked for defective motor capacitor. Be sure electrical supply and extension cords are adequate.
Noisy Operation	<ol style="list-style-type: none"> <li>1. Air in system.</li> <li>2. Be sure the oil reservoir is filled to normal level.</li> <li>3. Check all points where air might leak into system.</li> </ol>
Pump Oil is Over Heating	<ol style="list-style-type: none"> <li>1. Oil viscosity too high.</li> <li>2. Check for high-pressure leakage on upper pressure plate. (Leaking at plug).</li> <li>3. Oil level is low. Fill reservoir to normal level, or refit the pump with larger reservoir.</li> </ol>
Pump Runs but Will Not Pump Oil	<ol style="list-style-type: none"> <li>1. Pump is not primed. Run pump a few minutes tipping from side to side.</li> <li>2. Check to make sure that externally adjustable relief valve set properly. Check internal relief valve.</li> <li>3. Damaged O-Rings. Take to nearest authorized service center for repair.</li> <li>4. Defective control valve. (Troubleshoot separately).</li> </ol>



---

## 1.0 CHEMICAL PRODUCT AND COMPANY IDENTIFICATION

PRODUCT NAME: RYKON® OIL MV

MANUFACTURER/SUPPLIER:  
Amoco Oil Company  
200 East Randolph Drive  
Chicago, IL 60601

EMERGENCY HEALTH INFORMATION:  
1 (800) 447-8735

EMERGENCY SPILL INFORMATION:  
1 (800) 424-9300 CHEMTREC (USA)

OTHER PRODUCT SAFETY INFORMATION:  
(312) 856-3907

---

## 2.0 COMPOSITION/INFORMATION ON INGREDIENTS

COMPONENT	CAS#	RANGE % BY WEIGHT
Solvent refined heavy paraffinic distillate	64741-88-4	80-100

(See section 8.0 "Exposure Controls/Personal Protection" for exposure guidelines)

---

## 3.0 HAZARDS IDENTIFICATION

**EMERGENCY OVERVIEW:** This product has been evaluated and does not require any hazard warning on the label under OSHA criteria.

### POTENTIAL HEALTH EFFECTS:

**EYE CONTACT:** No significant health hazards identified.

**SKIN CONTACT:** Prolonged or repeated contact may produce some skin irritation. High-pressure equipment can inject this product through the skin and cause severe damage.

**INHALATION:** No significant health hazards identified.

**INGESTION:** No significant health hazards identified.

**HMIS CODE:** (Health:0) (Flammability:1) (Reactivity:0)

**NFPA CODE:** (Health:0) (Flammability:1) (Reactivity:0)

---

## 4.0 FIRST AID MEASURES

**EYE:** Flush eyes with plenty of water.

**SKIN:** Wash exposed skin with soap and water. Get medical attention if irritation develops. Get immediate medical attention following injection injuries.

**INHALATION:** If adverse effects occur, remove to uncontaminated area. Get medical attention.

**INGESTION:**

---

## 5.0 FIRE FIGHTING MEASURES

**FLASHPOINT:** 383°F (195°C) (Cleveland open cup)

**UEL:** Not Determined

**LEL:** Not Determined

**AUTOIGNITION TEMPERATURE:** Not Determined

**FLAMMABILITY CLASSIFICATION:** Not Flammable.

**EXTINGUISHING MEDIA:** Agents approved for Class B hazards (e.g. dry chemical, carbon dioxide, foam, steam) or water fog.

**UNUSUAL FIRE AND EXPLOSION HAZARDS:** None Identified.

**FIRE-FIGHTING EQUIPMENT:** Firefighters should wear full bunker gear, including a positive pressure self-contained breathing apparatus.

**HAZARDOUS COMBUSTION PRODUCTS:** Incomplete burning can produce carbon monoxide and/or carbon dioxide and other harmful products.

---

## 6.0 ACCIDENTAL RELEASE MEASURES

Prevent spreading by diking, ditching, or absorbing on inert materials. Keep out of sewers and waterways.

---

## 7.0 HANDLING AND STORAGE

**HANDLING:** No Special Requirements

**STORAGE:** No Special Requirements

---

## 8.0 EXPOSURE CONTROLS/PERSONAL PROTECTION

**EYE:** None required, however, use of eye protection is good industrial practice.

**SKIN:** Wear protective gloves if prolonged or repeated contact is expected.

**INHALATION:** None required, however, use of adequate ventilation is good industrial practice

**ENGINEERING CONTROLS:** Control airborne concentrations below the exposure guidelines

### EXPOSURE GUIDELINES:

COMPONENT	CAS#	EXPOSURE LIMITS
Solvent refined heavy paraffinic distillate	64741-88-4	OSHA PEL: 5mg/m <sup>3</sup> (oil mist) (1989) (1971) ACGIH TLV-TWA: 5 mg/m <sup>3</sup> (oil mist) ACGIH TLV-STEL: 10 mg/m <sup>3</sup> (oil mist)

## 9.0 CHEMICAL AND PHYSICAL PROPERTIES

<b>APPEARANCE AND ODOR:</b>	Oily liquid. Pale yellow
<b>pH:</b>	Not Determined
<b>VAPOR PRESSURE:</b>	Not Determined
<b>VAPOR DENSITY:</b>	Not Determined
<b>BOILING POINT:</b>	Not Determined
<b>MELTING POINT:</b>	Not Determined
<b>SOLUBILITY IN WATER:</b>	Negligible, below 0.1%
<b>SPECIFIC GRAVITY (WATER = 1)</b>	0.87
<b>VISCOSITY:</b>	32.4 – 39.66cSt at 40°C
<b>POUR POINT:</b>	-40oF (-40oC) (maximum)
<b>VISCOSITY INDEX:</b>	95 Minimum

---

## 10.0 STABILITY AND REACTIVITY

**STABILITY:** Stable

**CONDITIONS TO AVOID:** None identified

**MATERIALS TO AVOID:** Avoid chlorine, fluorine, and other strong oxidizers

**HAZARDOUS DECOMPOSITION:** None identified

**HAZARDOUS POLYMERIZATION:** Will not occur.

---

## 11.0 TOXICOLOGICAL INFORMATION

### ACUTE TOXICITY DATA:

**EYE IRRITATION:** Testing not conducted. See other toxicity data.

**SKIN IRRITATION:** Testing not conducted. See other toxicity data

**DERMAL LD50:** Testing not conducted. See other toxicity data

**ORAL LD50:** Testing not conducted. See other toxicity data

**INHALATION LC50:** Testing not conducted. See other toxicity data

### OTHER TOXICITY DATA:

Specific toxicity test have not been conducted on this product. Our hazard evaluation is based on information from similar products, the ingredients, technical literature, and/or professional experience.

No component of this product present at levels greater than 0.1% is identified as a carcinogen by the US National Toxicology Program, the US Occupational Safety and Health Act, or the International Agency on Research on Cancer (IARC).

---

## 12.0 ECOLOGICAL INFORMATION

Ecological testing has not been conducted on this product.

### 13.0 DISPOSAL INFORMATION

Disposal must be in accordance with applicable federal, state, or local regulations. Enclosed – controlled incineration is recommended unless directed otherwise by applicable ordinances. This material may be amenable to recycling.

Since the emptied containers retain product residue, follow label warnings even after container is emptied.

---

### 14.0 TRANSPORTATION INFORMATION

#### US DEPT OF TRANSPORTATION

**Shipping Name: Not Regulated**

#### INTERNATIONAL INFORMATION

##### Sea (IMO/IMDG)

**Shipping Name: Not Determined**

##### Air (ICA/IATA)

**Shipping Name: Not Determined**

##### European Road/Rail (ADR/RID)

**Shipping Name: Not Determined**

##### Canadian Transportation of Dangerous Goods

**Shipping Name: Not Determined**

---

### 15.0 REGULATORY INFORMATION

CERCLA SECTIONS 102A/103 HAZARDOUS SUBSTANCES (40 CFR PART 302.4): This product is not reportable under 40 CFR Part 302.4

SARA TITLE III SECTION 302 EXTREMELY HAZARDOUS SUBSTANCES (40 CFR PART 355): This product is not regulated under Section 302 of SARA and 40 CFR Part 355

SARA TITLE III SECTIONS 311/312 HAZARDOUS CATEGORIZATION (40 CFR PART 370): This product is not regulated under SARA Title III Section 311/312

SARA TITLE III SECTION 313 (40 CFR PART 372): This product is not regulated under Section 313 of SARA and 40 CFR Part 372

US INVENTORY (TSCA): Listed on inventory

This product contains n-methyl pyrrolidone (CAS 872-50-4) which is currently undergoing review and testing under TSCA Section 4. Notification to the US EPA Office of Toxic Substances is required prior to export of this material from the United States.

OSHA HAZARD COMMUNICATION STANDARD: Contains a component listed by OSHA. Contains a component listed by ACGIH

EC INVENTORY (EINECS/ELINCS): Not Determined

JAPAN INVENTORY (MITI): Not Determined

AUSTRALIA INVENTORY (AICS): Not Determined

KOREA INVENTORY (DSL): Not Determined

CANADA INVENTORY (DSL): Not Determined

PHILIPPINE INVENTORY (PICCS): Not Determined

FOOD CONTACT STATUS:

USDA: H2 Status. This product is acceptable to the USDA for use as a lubricant in official meat and poultry establishments provided there is no possibility of the lubricant or lubricated part contacting edible products.

## 16.0 OTHER INFORMATION

Prepared by

Environmental Health and Safety Department

Issued: September 20, 1993

This Material Safety Data Sheet conforms to the requirements of ANSI z400.1

This material safety data sheet and the information it contains are offered to you in good faith as accurate. We have reviewed any information contained in this data sheet, which we received from sources outside our company. We believe the information to be correct, but cannot guarantee its accuracy or completeness. Health and safety precautions in this data sheet may not be adequate for all individuals and/or situations. It is the user's obligation to evaluate and use this product safely and to comply with all applicable laws and regulations. No statement made in this data sheet shall be construed as a permission or recommendation for the use of any product in a manner that might infringe existing patents. Not warranty is made, either express or implied.

# EP1000 Q 230V Electric Power Pump

# Common components used in pumps

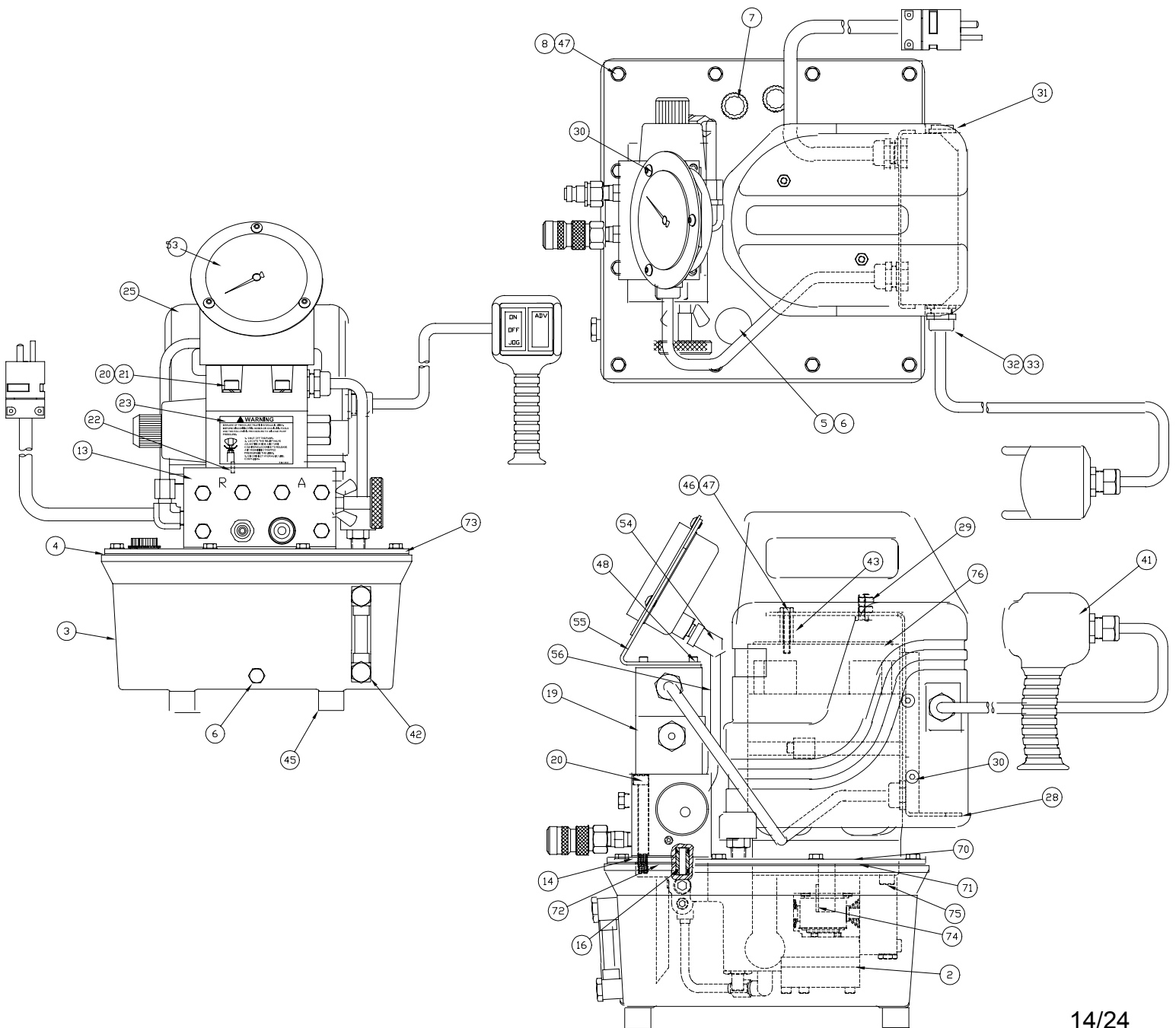

# EP1000 Q 230V Electric Power Pump

# Common components used in pumps

ITEM #	PART #	DESCRIPTION	QTY.
02	45830	PUMP ASM HIGH FLOW 1.5 HP	1.00
03	44978	2 GAL RES. W/DRAIN & SIGHT GAUGE	1.00
04	66014	GASKET RES 2 GAL	1.00
05	68000	BREATHER VENT BF-4	1.00
06	43380	HEX PIPE PLUG 1/4 SS	2.00
07	68571	FILLER PLUG	2.00
08	43364	HHCS 1/4-20X5/8 SS	12.00
13	43384	MANIFOLD ASM TORQUE	1.00
14	68722	VALVE GASKET TORQUE	1.00
16	68963	ADAPTER ASSY.	1.00
19	44866	VALVE 2P ADV/RET230V	1.00
20	43362	SHCS 3/8-16X3.5 SS	7.00
21	Y0010260	LOCKWASHER 3/8" 316SS	4.00
22	561604	ROLL PIN 1/8X3/8 LG	1.00
23	45804	WARNING LABEL PRESSURE TRAP	1.00
25	69938	SHROUD MACHINED YLLW	1.00
28	44650	MTG BRK ASM TORQ 70S	1.00
29	43366	HEAVY HEX NUT 1/4-20	2.00
30	43365	BHCS 10-24X.25 316SS	7.00
31	69159	SWITCH 8961K385	1.00
32	68375	FITTING,CORD L-TIGHT	1.00
33	85510	LOCKNUT 1/2 INCH	1.00
37	65888	PUSH-ON TERMINAL	4.00
38	65887	SPADE, TERMINAL	1.00
39	69267	#4 JUMPER WIRE X 20"	2.00
41	45623	PENDANT TORQUE WRENCH	1.00
42	69284	GAGE LIQUID LEVEL	1.00
43	69353	SPACER	2.00
44	69427	TERMINAL PUSH ON	1.00
45	69479	RUBBER FOOT VBM-3005	4.00
46	84417	HHCS 1/4-20X1.5 LG.	2.00
47	88429	WASHER SS 1/4"	14.00
48	43358	SHCS #10-32X.25 316SS	4.00
51	98250	SCREW, FILL HD MACH	-3.00
53	45724	PRESSURE GAUGE W/ FLANGE TORC-UP	1.00
54	43166	ELBOW 90 1/4NPT 3/8T	1.00
55	43407	GAUGE BRACKET PLATED	1.00
56	43378	TUBE ELEC T-WRENCH P	1.00
70	66012	GASKET-MOTOR	1.00
71	68231	GASKET-PUMP @ MOTOR	1.00
72	68551	GASKET-PUMP @ VALVE	1.00
73	69526P	COVER PLATE 2G TORQUE WRENCH BLACK	1.00
74	69026	PIN,DOWEL 3/16 1 .	1.00
75	93596	SHCS 3/8-16X1-1/4	2.00
76	68403	ELEC. MOTOR PM250	1.00

# EP1000 Q 230V Electric Power Pump

# Sub Pump Assembly

(45830) PUMP ASM.

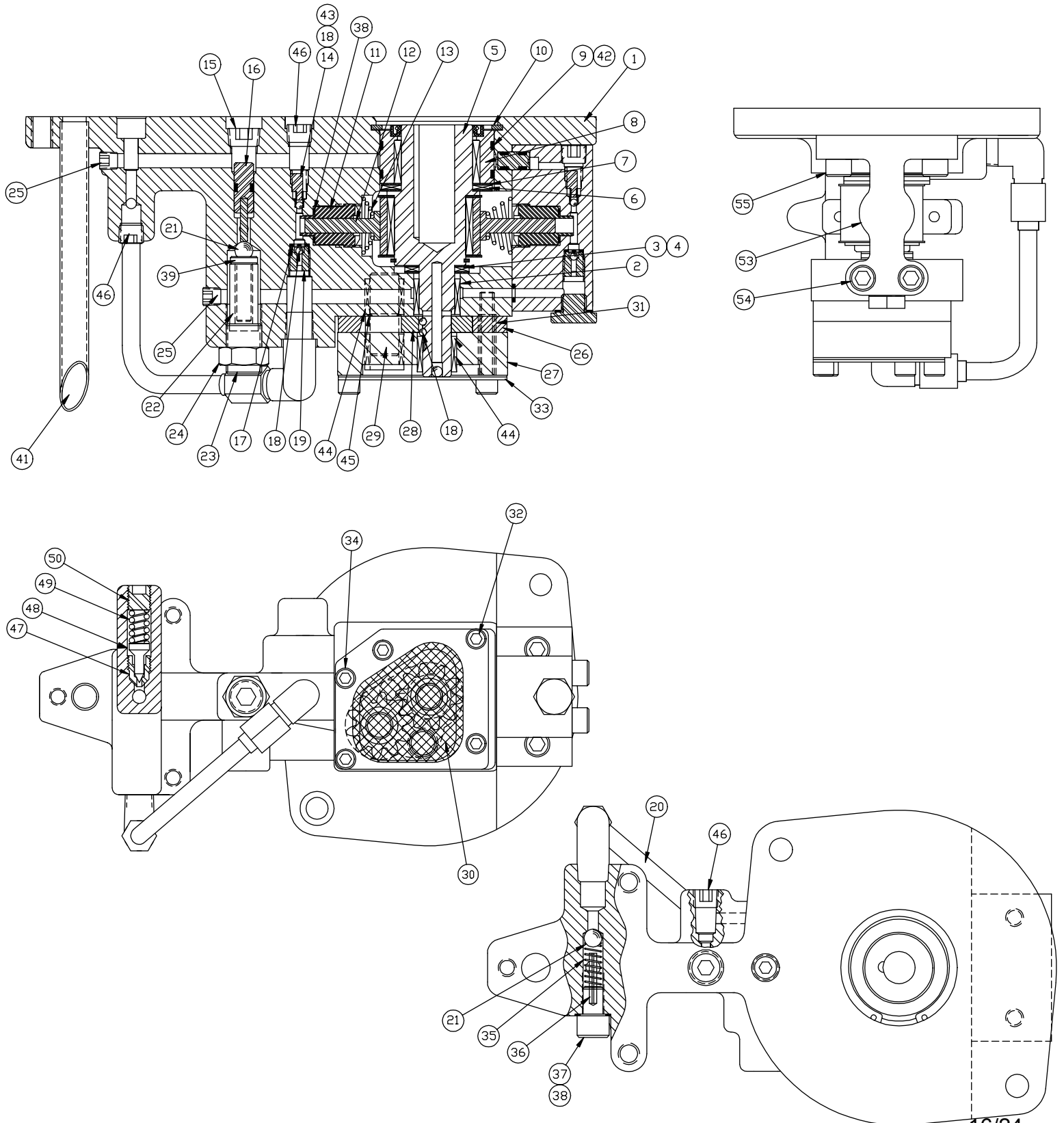



# EP1000 Q 230V Electric Power Pump

# Sub Pump Assembly

## (45830) PART LIST

ITEM	PART #	DESCRIPTION	QTY
01	43769	PUMP BODY 2 PISTON	1.00
02	68360	BEARING, ROLLER	1.00
03	66033	THRUST BEARING	1.00
04	66474	THRUST WASHER	2.00
05	69082	ECCENTRIC SHAFT ASSEMBLY	1.00
06	66106	THRUST BEARING	1.00
07	66108	THRUST WASHER	2.00
08	68829	ADAPTER-SHAFT ASM	1.00
09	56020322	O-RING 1 7/8X2" URE	2.00
10	68978	RETAINING RING	1.00
11	68909	ADAPTOR .255 DIA.	1.00
12	68222	PISTON .255 DIA.	1.00
13	68340	SPRING, PISTON	1.00
14	68810	BALL STOP	1.00
15	93950	1/4 SOC PIPE PLUG	1.00
16	43766	UNLOADING PISTON ASSEMBLY	1.00
17	66043	BALL RETAINER	1.00
18	90906	BALL 1/8"	5.00
19	66046	INTAKE SEAT	1.00
20	68851	TUBE ASM	1.00
21	91701	BALL 5/16"	2.00
22	43671	UNLOADING SPRING	1.00
23	43674	SET SCREW UNLOADING VALVE	1.00
24	43675	HEX NUT UNLOADING VALVE	1.00
25	97641	1/16 SOC PIPE PLUG	2.00
26	45823	CENTER PLATE 0.281	1.00

ITEM	PART #	DESCRIPTION	QTY
27	68849	PLATE-BOTTOM	1.00
28	45824	GEAR PUMP 0.281	2.00
29	68850	SHAFT-IDLER	1.00
30	68921	SCREEN	1.00
31	68894	TUBE-GUIDE .11	2.00
32	68255	SHCS 1/4-28 X 1 3/4	4.00
33	68927	PLATE-SCREEN MTG.	1.00
34	89148	SHCS 1/4-28 X 1 1/2	1.00
35	68225	SPRING	1.00
36	81332	ROLL PIN 1/8X15/16	1.00
37	68226	SCREW, BALL STOP	1.00
38	85726	GASKET 25/64X19/32	2.00
39	43673	SPRING CAP UNLOADING VALVE	1.00
41	68569	TUBE RETURN	1.00
42	69513	SHAFT ADP BACKUP WAS	2.00
43	66042	SPRING	1.00
44	68891	BEARING	3.00
45	68892	RING-RETAINING	1.00
46	81093	PIPE PLUG 1/8" FLUSH	2.00
47	68004	SEAT - EXT RELIEF	1.00
48	68003	CONE - EXT RELIEF	1.00
49	66085	SPRING - RELIEF VALVE	1.00
50	66083	RELIEF VALVE ADJUSTING SCREW	1.00
53	68898	PISTON BLK .255	1.00
54	69392	SHCS 5/16-24 X 1.75	2.00
55	82687	SHCS 5/16-24 X 5/8	2.00

# EP1000 Q 230V Electric Power Pump

## Sub Component Assemblies

### (68829) ADAPT-SHAFT ASM.

ITEM #	DESCRIPTION	PART #	QTY.
01	ADAPTER SHAFT	68912	1.00
02	BEARING	66030	1.00
03	SEAL	68901	1.00

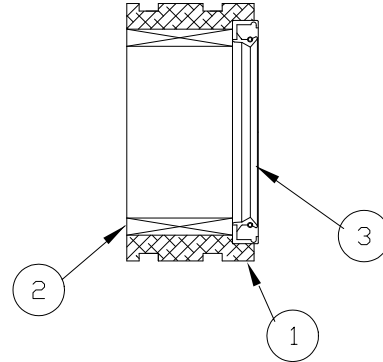

### (43766) UNLOAD. PISTON ASM.

ITEM #	DESCRIPTION	PART #	QTY.
01	UNLOAD PISTON	43765	1.00
02	O RING	5602009	1.00
03	BACK-UP WASHER	43768	1.00
04	ROLL PIN	43686	1.00

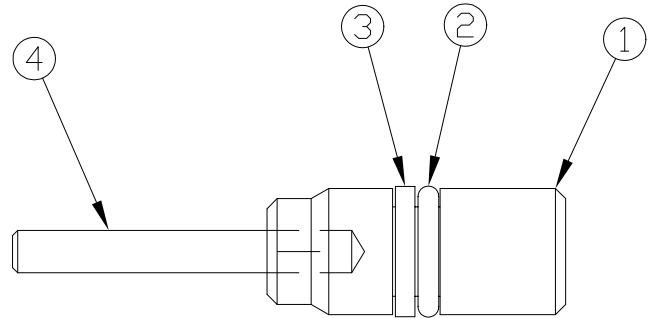

### (69082) ECCENTRIC SHAFT ASM.

ITEM #	DESCRIPTION	PART #	QTY.
01	ECCENTRIC SHAFT	68859	1.00
02	BEARING	69081	1.00
03	BEARING WASHER	69475	2.00
04	RET. RING	67863	1.00
05	BALL	90548	1.00

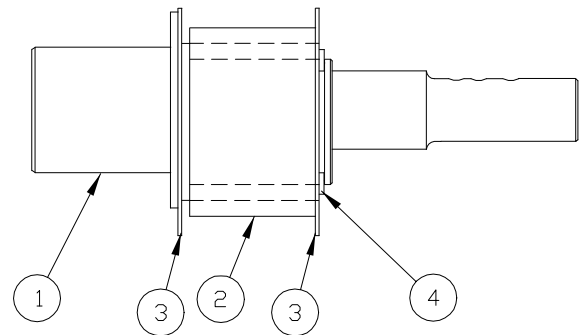

### (68963) ADAPTER ASM.

ITEM #	DESCRIPTION	PART #	QTY.
01	VALVE ADAPTER	88073	2.00
02	B-U RING	65881	2.00
03	VALVE ADAPTER	5602012	1.00

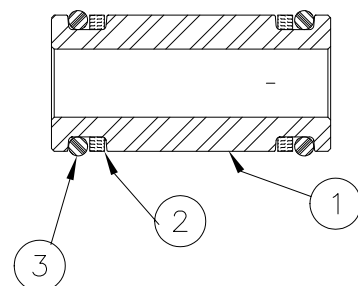

# EP1000 Q 230V Electric Power Pump

# Sub Component Assemblies

## (68898) PISTON BLK.

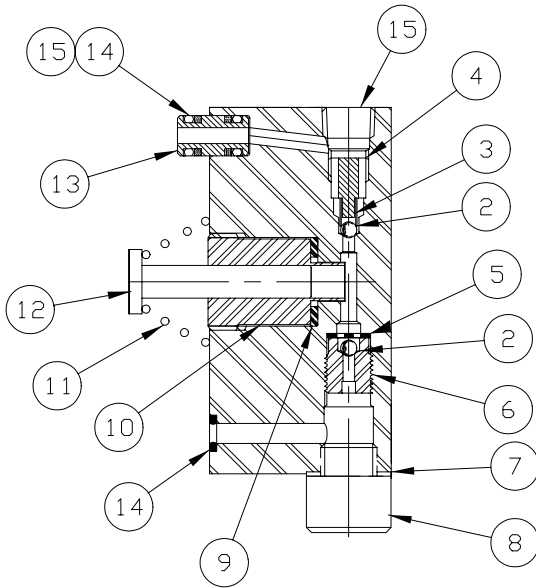

ITEM #	PART #	DESCRIPTION	QTY.
01	68501	PISTON BLOCK MACH'G	1.00
02	90906	BALL 1/8"	2.00
03	66042	SPRING	1.00
04	68810	BALL STOP	1.00
05	66043	BALL RETAINER	1.00
06	66046	INTAKE SEAT	1.00
07	86269	GASKET 29/64 X 5/8	1.00
08	68825	SCREW	1.00
09	85726	GASKET 25/64X19/32	1.00
10	68909	ADAPTOR .255 DIA.	1.00
11	68340	SPRING, PISTON	1.00
12	68222	PISTON .255 DIA.	1.00
13	68970	ADAPTER ASSY.	1.00
14	5602008	O-RING 3/16X5/16	1.00
15	81093	PIPE PLUG 1/8" FLUSH	1.00

## (68999) INTERNAL RELIEF ASM.

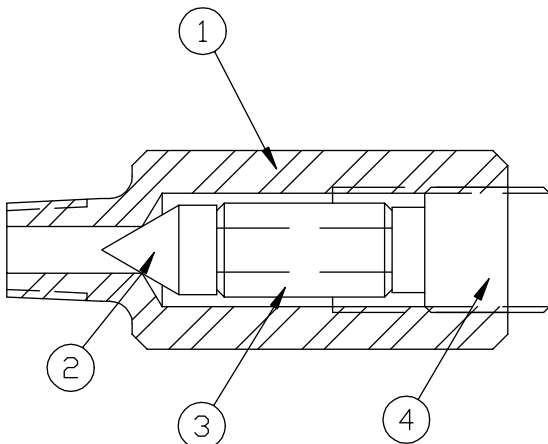

ITEM	PART #	DESCRIPTION	QTY.
01	68998	CART.INT.RELIEF HF	1.00
02	66086	CONE REL VLVE	1.00
03	66085	SPRING - RELIEF VALVE	1.00
04	88788	1/2-20 SOC.SET SCREW	1.00

# EP1000 Q 230V Electric Power Pump

# Valve Sub Assembly

(44866) VALVE 2 POSITION 230V.

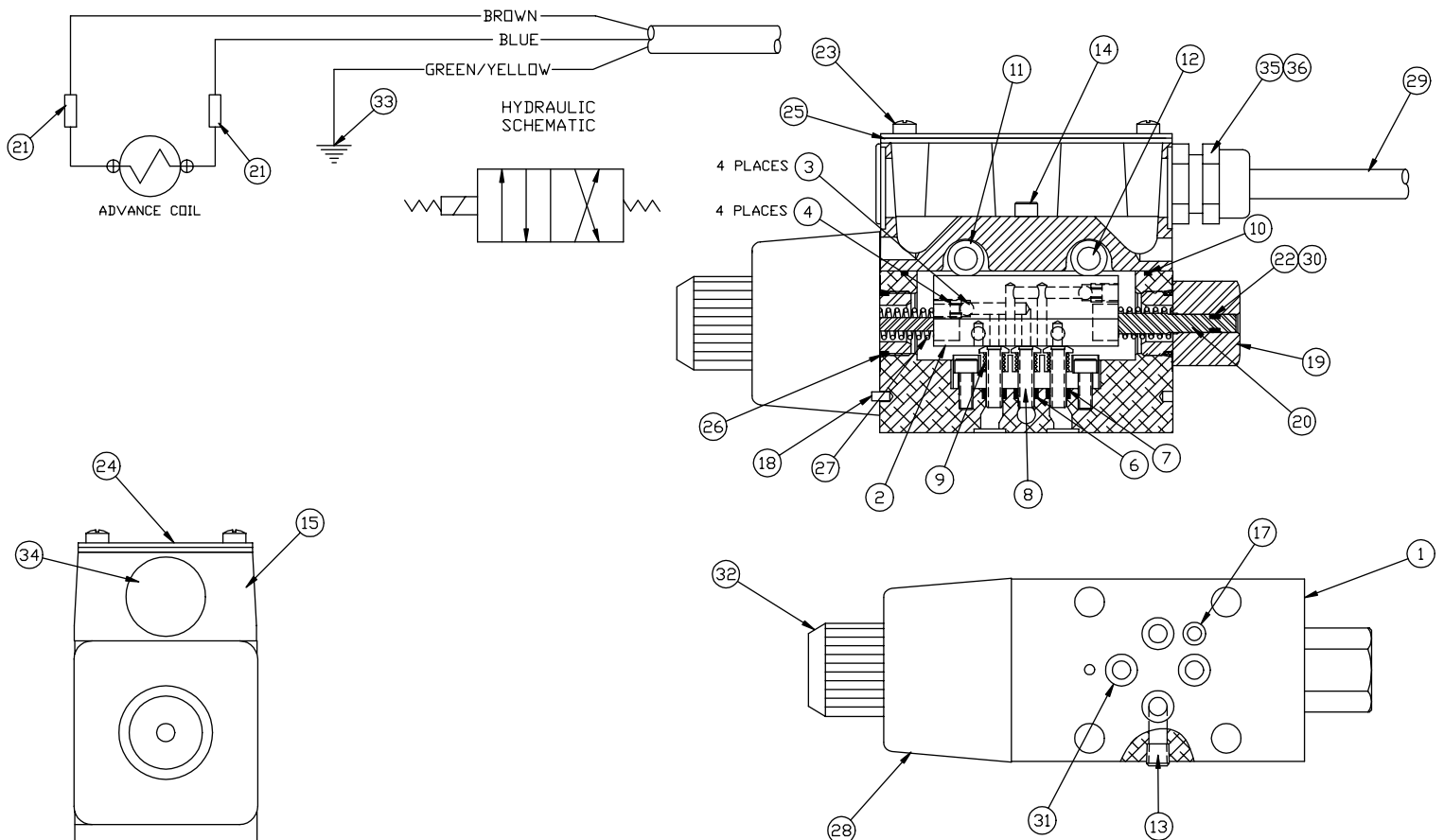

ITEM	PART #	DESCRIPTION	QTY
01	68708	BODY-VALVE	1.00
02	44328	SLIDER ADV/RET ONLY	1.00
03	90548	BALL 3/16"	4.00
04	40254	SET SCREW 1/4-28X1/4	4.00
06	5602009	O-RING 7/32X11/32	3.00
07	68391	BACK UP WASHER	3.00
08	68383	SHEAR SEAL	3.00
09	68384	SPRING	3.00
10	5602038	O-RING 2 5/8 X 2 3/4	1.00
11	68385	BEARING,ROLLER	4.00
12	68390	PIN BEARING	2.00
13	40049	1/16 PIPE PLUG-FLUSH	1.00
14	68264	SHCS 10-32 X 1" LG	2.00
15	68381	PLATE-TOP MACHINING	1.00
17	5602008	O-RING 3/16X5/16	1.00
18	69636	ROLL PIN 1/8X1/4 LG	1.00
19	69177	ADAPTER	1.00
20	69178	PUSHER PIN	1.00

ITEM	PART #	DESCRIPTION	QTY
21	66132	BUTT CONNECTOR	2.00
22	5602006	O-RING 1/8 X 1/4	1.00
23	98250	SCREW, FILL HD MACH	4.00
24	68388	COVER, VALVE	1.00
25	68389	GASKET CVR	1.00
26	5603910	O-RING SAE PORT #10	2.00
27	68711	SPRING	2.00
28	68730	COIL 115VAC K1649345	1.00
29	69604R	POWER CORD 14-3 IEC	30.00
30	5608006	BACK-UP WASHER	1.00
31	56020112	O-RING 5/16X7/16 URE	4.00
32	68729	PUSHER-SOLENOID	1.00
33	65887	SPADE, TERMINAL	1.00
34	44679	HOLE PLUG 13/16 PLAS	1.00
35	68375	FITTING,CORD L-TIGHT	1.00
36	85510	LOCKNUT 1/2 INCH	1.00

# Manifold Assembly

**EP1000 Q 230V**

**Electric Power Pump**

**(43384) MANIFOLD ASM.**

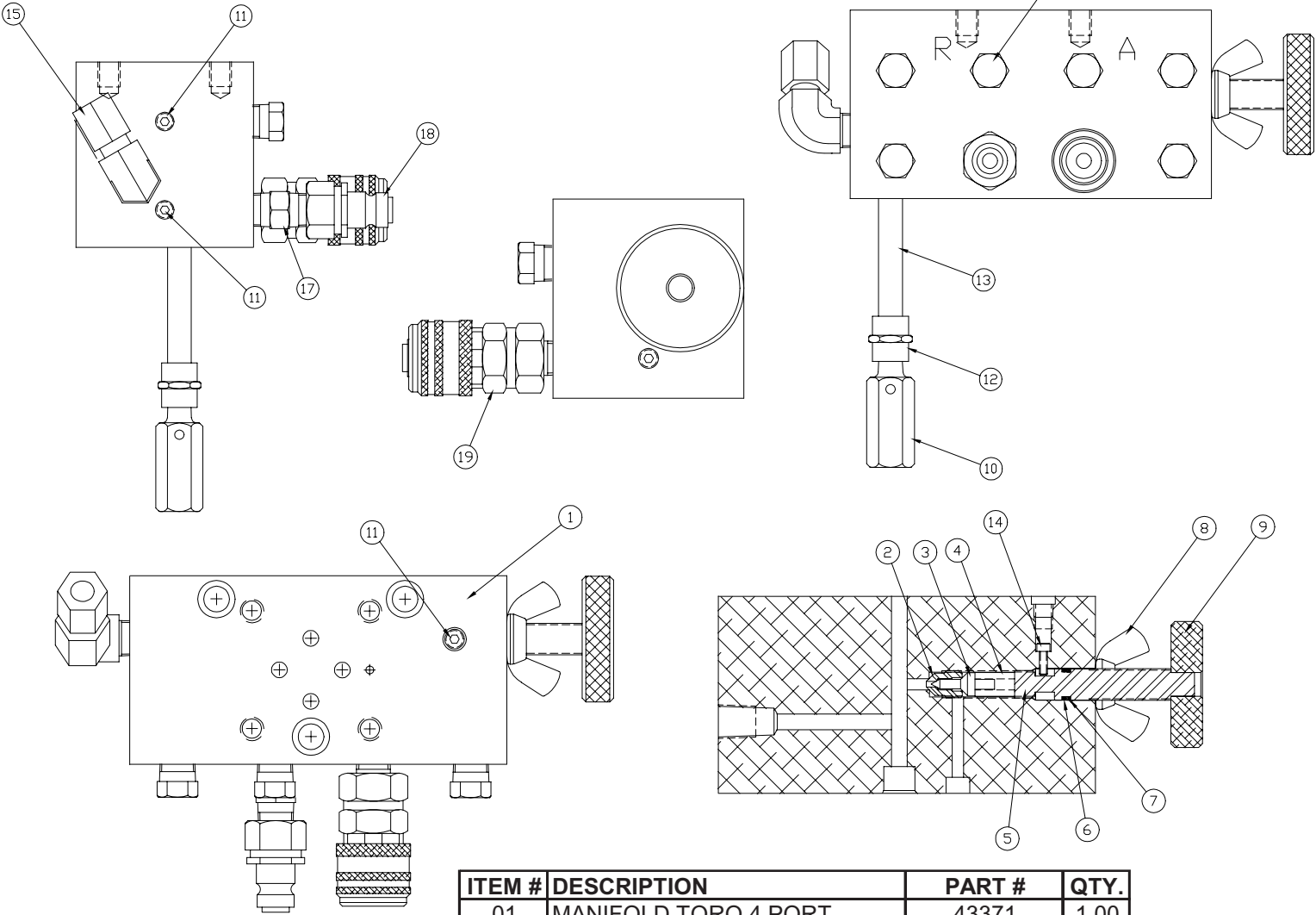

ITEM #	DESCRIPTION	PART #	QTY.
01	MANIFOLD TORQ 4 PORT	43371	1.00
02	SEAT - EXT RELIEF	68004	1.00
03	CONE - EXT RELIEF	68003	1.00
04	RELIEF SPRING TORQ W	45074	1.00
04	SPRING - RELIEF VALVE	66085	1.00
05	ADJ STEM TORQUE WREN	68655	1.00
06	O-RING 3/8X1/2	5602012	1.00
07	B-U RING	65881	1.00
08	ADJ WING NUT	68695	1.00
09	ADJ KNOB	88508	1.00
10	INT.RELIEF ASM HF	68999	1.00
11	1/16 PIPE PLUG-FLUSH	40049	5.00
12	PIPE COUPLING 1/8	68918	1.00
13	PIPE NIPPLE 1/8 NPT	68917	1.00
14	SHCS #5-40 X 3/8 LG	69372	1.00
15	MALE ELBOW 3/8-1/4	89698	1.00
16	HEX PIPE PLUG 1/4 SS	43380	6.00
17	1/4 IN NIPPLE	4100067	1.00
18	1/4" NIPPLE	CT210	1.00
19	1/4" SELF-LOCKING COUPLER	45765	1.00

# EP1000 Q 230V Electric Power Pump

# Bracket Sub Assembly

## (44650) MOUNTING BRACKET ASM.

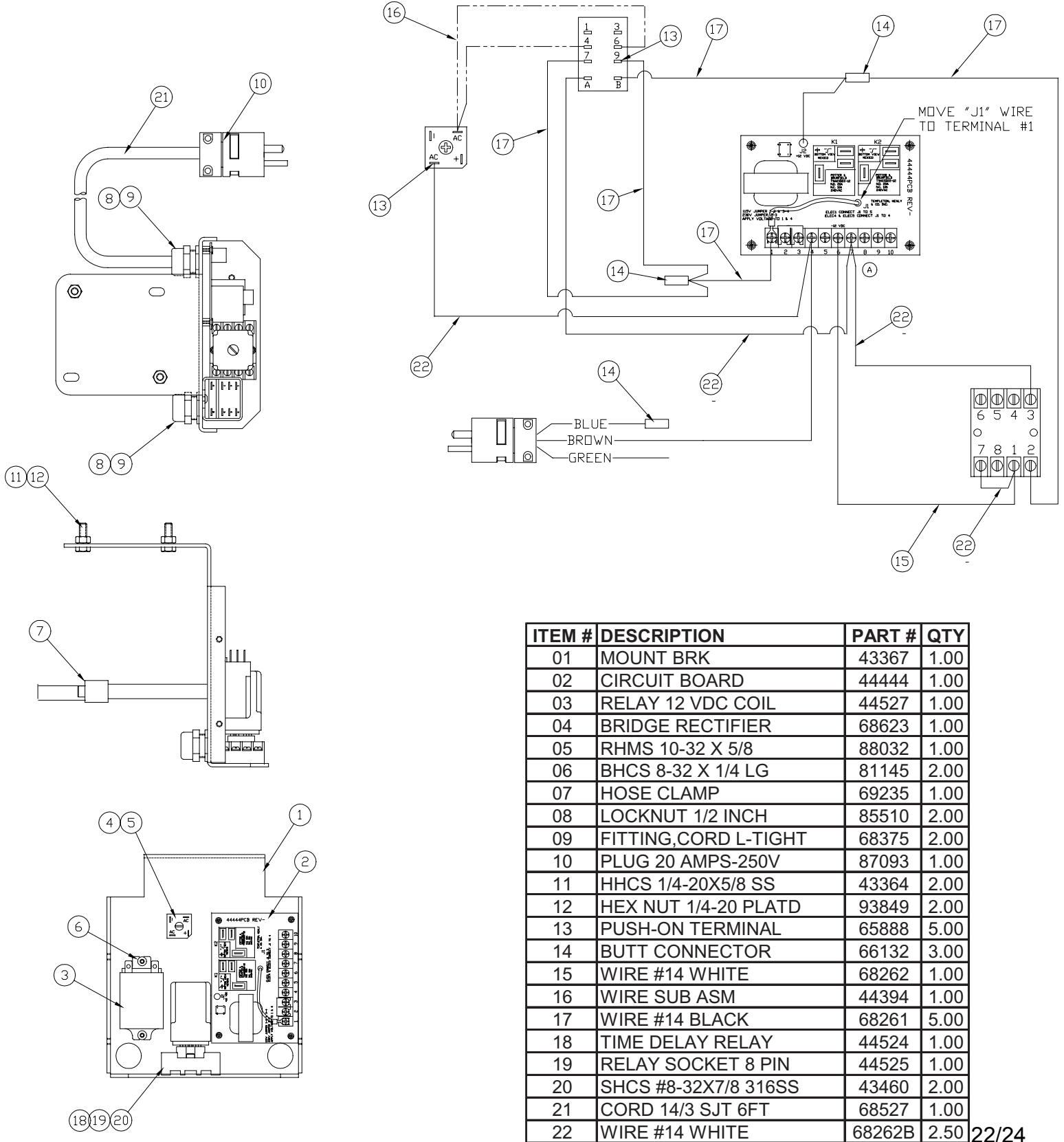

# EP1000 Q 230V Electric Power Pump

# Wire Configuration

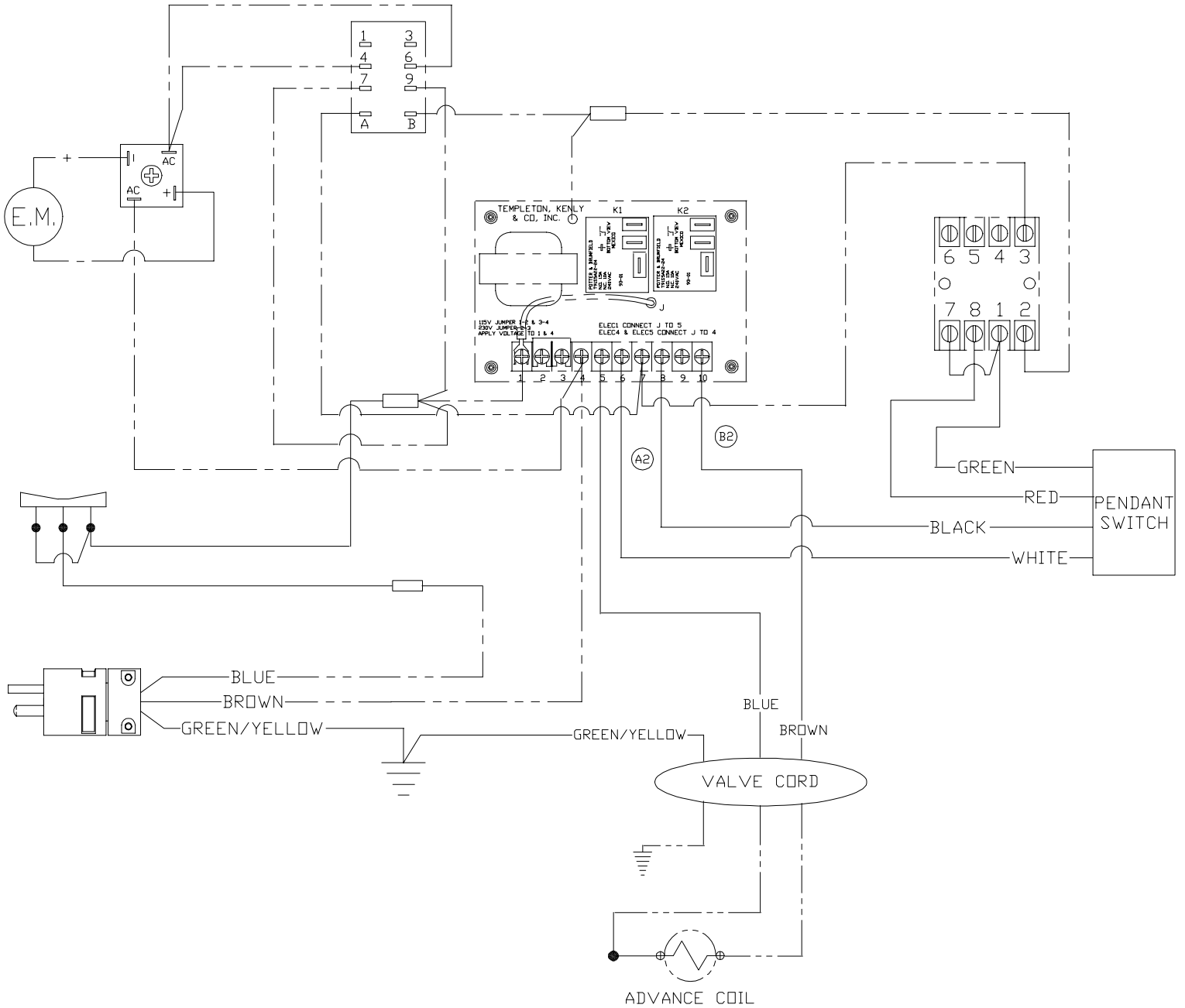

# EP1000 Q 230V Electric Power Pump

# Pendant Control

## (45623) PENDANT ASM.

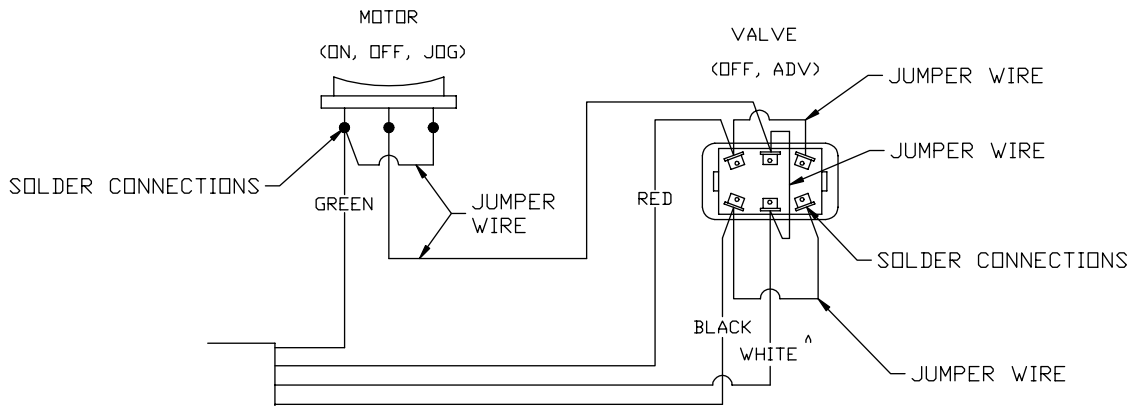
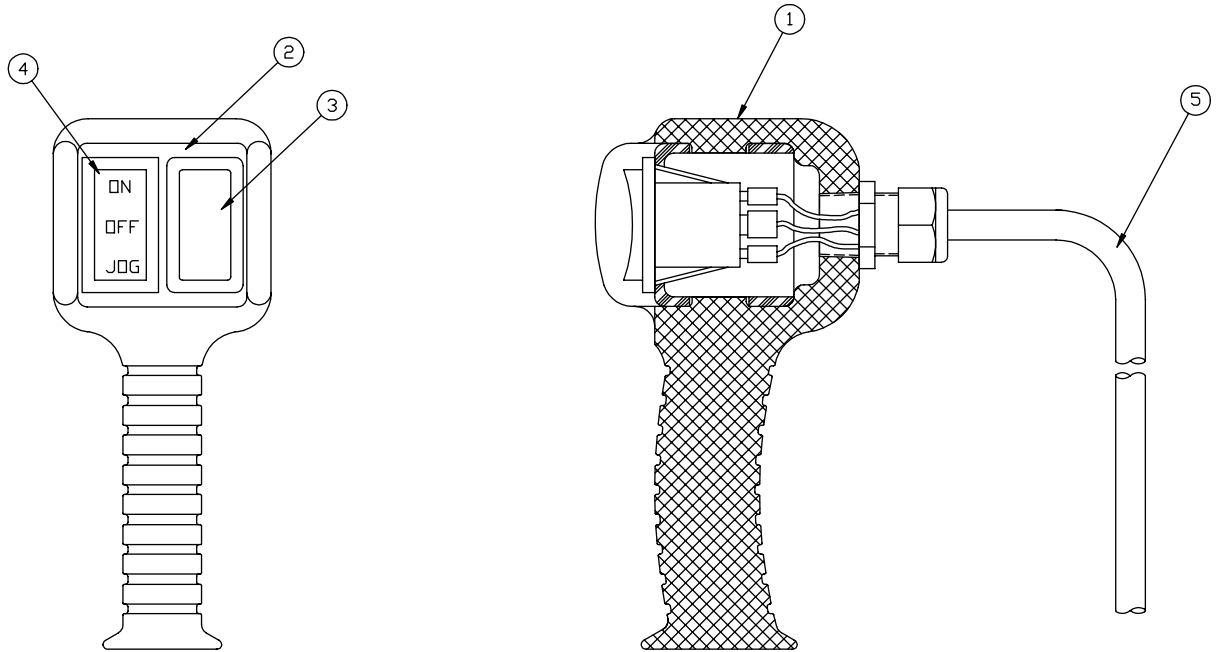

ITEM	PART #	DESCRIPTION	QTY
01	69083	PENDANT BODY& RELIEF	1.00
02	69151	JUNCTION BOX 2SWITCH	1.00
03	69487	SWITCH ON MOMENTARY	1.00
04	69159	SWITCH 8961K385	1.00
05	69370	PENDANT CORD	1.00