

# **SIMPLEX**®

## ***S2000A & S3000A HYDRAULIC SPREADERS***

Operating Instructions Manual  
For 1.0 & .75 Ton Hydraulic Spreaders  
S2000A & S3000A Models  
Reference # 54486  
Revision B  
01/2008

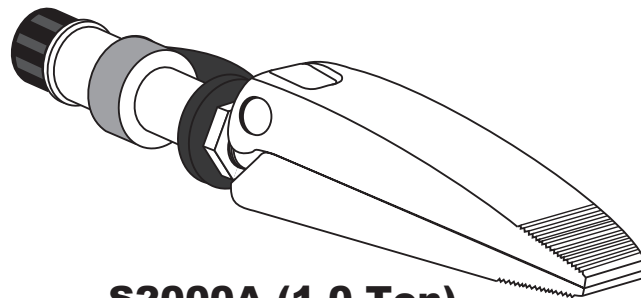

**S2000A (1.0 Ton)**

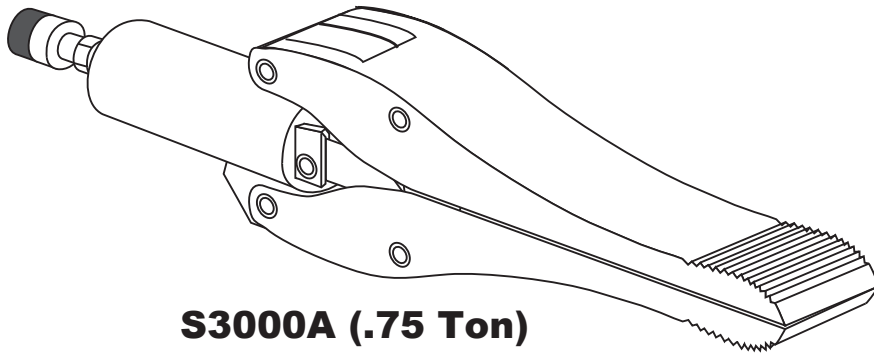

**S3000A (.75 Ton)**

**Table of Contents**  
**1.0 Receiving Instructions**  
**2.0 Safety**  
**3.0 Specifications**  
**4.0 Initial Installation**  
**5.0 Operation**  
**6.0 Maintenance**  
**7.0 Troubleshooting**

# INDEX – S2000A & S3000A HYDRAULIC SPREADERS

## WARRANTY STATEMENT

**SIMPLEX** products are warranted to be free of defects in materials and workmanship under normal use for as long as the original purchaser owns them, subject to the guidelines and limitations listed. This warranty does not cover: normal wear & tear, cosmetic items, abuse, overloading, alterations, improper fluid, or use in a manner for which they are not intended. If the customer believes a product is defective, the product must be delivered, or shipped freight prepaid, to the nearest SIMPLEX Authorized Service Center for evaluation and repair.

## **OPERATING INSTRUCTIONS AT A GLANCE**

### **1.0 RECEIVING INSTRUCTIONS**

Important! Make sure to inspect all of the components for shipping damage. If damage is found, notify carrier at once. Shipping damage will not be covered by warranty. The carrier is responsible for all loss associated to shipping damage.

### **2.0 SAFETY**



Make sure to read the instructions, warning and precautions carefully. Follow any recommended safety precautions to avoid personal injury or damage to the unit. Simplex cannot be responsible for any damage or injury from unsafe use, lack of maintenance or incorrect operation. In the event any questions or concerns arise, contact SIMPLEX or a local Distributor for clarification.

If you have never been trained on high-pressure hydraulic safety, consult your distributor or service center for a free Simplex Hydraulic Safety Course.

**Failure to comply with the following cautions and warnings could cause equipment damage, property damage or personal injury.**

**CAUTION** is used to indicate correct operating or maintenance procedures and practices to prevent damage to, or destruction of equipment or other property.

**WARNING** indicates a potential danger that requires correct procedures or practices to avoid personal injury.

**DANGER** is only used when your action or lack of action may cause serious injury or even death.

***WARNING:*** Wear proper personal protective gear when operating hydraulic equipment.

*Never set the relief valve to a higher pressure than the maximum rated pressure of the pump. Higher settings may result in equipment damage and/or personal injury.*

***DANGER:*** To avoid personal injury, keep hands and feet away from spreader and work-piece during operation.

***WARNING:*** The system operating pressure must not exceed the pressure rating of the lowest rated component in the system. Install pressure gauges in the system to monitor operating pressure. It is your window to what is happening in the system.

***WARNING:*** Do not exceed equipment ratings. Never attempt to spread a load weighing more than the capacity of the spreader specifications. Overloading causes equipment failure and possible personal injury. The tools are designed for a max. pressure of 10,000 PSI (700kg/cm<sup>2</sup>). Do not connect a spreader to a pump with a higher pressure rating.

***CAUTION:*** Avoid damaging hydraulic hose. Avoid sharp bends and kinks when routing hydraulic hoses. Using a bent or kinked hose will cause severe back-pressure. Sharp bends and kinks will internally damage the hose, leading to premature hose failure.

Do not drop heavy objects on hose. A sharp impact may cause internal damage to hose wire strands. Applying pressure to a damaged hose may cause it to rupture.

**IMPORTANT:** Do not lift hydraulic equipment by the hose or swivel couplers. Use other means of safe transport.

**CAUTION:** Keep hydraulic equipment away from flames and heat. Excessive heat will soften packing and seals, resulting in fluid leaks. Heat also weakens hose materials and packing. For optimum performance do not expose equipment to temperatures of 65° C (150° F)

or higher. Protect hoses and spreaders from weld spatter.

**DANGER:** Do not handle pressurized hoses. Escaping oil under pressure can penetrate the skin, causing serious injury. If oil is injected under the skin, see a doctor immediately.

**DANGER:** Only use hydraulic spreaders in a coupled system. Never use a spreader with unconnected couplers. If the spreader becomes severely overloaded, components can fail catastrophically causing severe personal injury or death.

### 3.0 SPECIFICATIONS

COMPONENT	S2000A	S3000A
MAX. OPERATING PRESSURE	10,000 PSI (700kg/cm <sup>2</sup> )	
CAPACITY (TONS)	1	0.75
STROKE IN. (CM)	3.5 (8.89)	11.5 (29.2)
A. IN (CM)	8.78 (22.3)	21.7 (55.0)
B. IN (CM)	3.70 (9.40)	11.5 (29.21)
C. IN (CM)	0.38 (0.97)	1.26 (3.20)
OIL CAPACITY	0.61 in <sup>3</sup>	3.91 in <sup>3</sup>
WEIGHT.	5 lbs.	25 lbs.
MAX OPERATING TEMPERATURE	170° F	

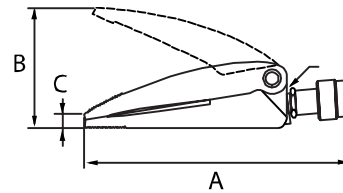

S2000

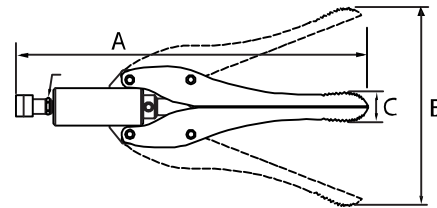

S3000

### 4.0 INITIAL INSTALLATION BEFORE OPERATING PUMP

#### 4.1 Working Pressure

The Tool's maximum working pressure is 10,000 PSI (700kg/cm<sup>2</sup>). Make sure that all hydraulic equipment such as pumps, hoses, etc. used with this spreader are rated at 10,000 PSI (700kg/cm<sup>2</sup>) operating pressure, refer to the table above for details.

#### 4.2 Install Hydraulic Connections

When making connections with quick disconnect couplings, make sure the couplings are fully engaged. Threaded connections such as fittings, gauges, etc. must be securely tightened and leak free. Attach hose to 3/8" NPT port. Connect matching coupler halves together hand tight only.

**WARNING:** Loose or improperly threaded fittings can be potentially dangerous if pressurized, however, severe over tightening can cause premature thread failure. Fittings need to be tightened secure & leak free. Never hold or stand directly in line with any hydraulic connections while pressurizing. Never grab, touch or in any way come in contact with a hydraulic pressure leak. Escaping oil can penetrate the skin and a serious injury can result.

**CAUTION:** Do not subject the hose to potential hazards such as sharp surfaces, extreme heat or heavy impact. Do not allow the hose to kink or twist. Inspect each hose for wear before it is used.

## **5.0 OPERATION**

Refer to the instruction sheet supplied with your pump for information on installing and operating your pump source.

1. Check the oil level in the pump.
2. Make sure all connections are tight and leak free.
3. Remove air from the system by placing the tool at a lower level than the pump and cycling the tool several times until the motion is smooth.
4. Operate the pump to spread the cylinder jaws. The jaws will close automatically when the pressure is released. The speed of retraction is dependent on the length of the hose and other restrictions in the line.

**CAUTION:** *Keep hands away from the pivot point of spreader jaws.*

### **5.2 After Completing the Job**

Before disconnecting hoses, fittings, etc., first be sure the tool is unloaded and retracted, shift the hydraulic controls several times to release system pressure. Store the spreader in a clean, dry area.

## **6.0 MAINTENANCE**

Use dust caps on couplers when tool is disconnected to prevent dirt from entering the system. Keep parts clean. Inspect all components for damage or wear before and after use.

## **7.0 TROUBLESHOOTING**

Problem	Possible Cause	Solution
Tool does not advance, advances slowly, or advances in spurts.	Oil level in pump reservoir is low.	Add oil according to the pump instructions.
	Pump release valve open.	Close pump release valve.
	Loose hydraulic coupler.	Check that all couplers are fully tightened.
	Load is too heavy.	Do not attempt to lift more than rated tonnage.
	Air trapped in system.	Remove air according to the instructions above.
	Cylinder plunger binding.	Check for damage to cylinder. Have cylinder serviced by a qualified hydraulic technician.
Tool advances, but does not hold pressure.	Leaking connection.	Check that all connections are tight and leak free.
	Leaking tool seals.	Locate leak(s) and have equipment serviced by a qualified hydraulic technician.
	Internal leakage in pump.	Have pump serviced by a qualified hydraulic technician.
Tool does not retract, retracts part way, or retracts more slowly than normal.	Pump release valve closed.	Open pump release valve.
	Pump reservoir is over-filled.	Drain oil level to full mark. See pump instructions for adding oil.
	Loose hydraulic coupler.	Check that all couplers are fully tightened.
	Air trapped in system.	Remove air according to the instructions above.
	Hose I.D. too narrow.	Use larger diameter hydraulic hose.
	Cylinder retraction spring broken or other cylinder damage.	Have cylinder serviced by a qualified hydraulic technician.

**To Retrieve Technical Part Sheet Documentation**  
**Go To [www.tksimplex.com](http://www.tksimplex.com)**